



MOREVIEW WINDOW SYSTEM

slim-frame windows

TM 77N MV OKNO MOREVIEW - SYSTEM ADVANTAGES

AESTHETICS

Maximum glazing area, minimal profile visibility both from the outside and the inside
Visible section from the outside 36 mm.
Visible section from the inside 67 mm.
Fixed mullion 50 mm

DESIGN

A handle with a unique design has been applied: invisible, concealed within the profile. The profile without an internal clip ensures a perfectly uniform line without unnecessary divisions.

DRAINAGE CONCEALED WITHIN THE PROFILE

No front drainage, giving the façade an even more minimalist appearance.

MODERN GLASS INSTALLATION TECHNOLOGY

The use of adhesive tapes accelerates the window prefabrication process.



View product
on the website

Photo: Example application of the system.

HORIZONTAL SECTION
of an opening window with side light

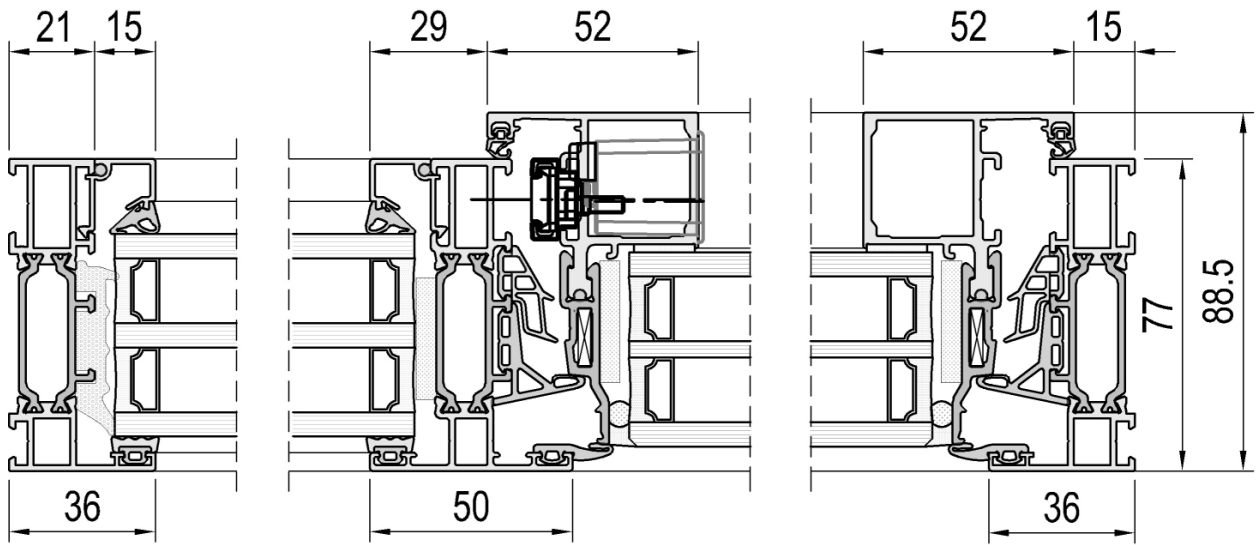

TECHNICAL PARAMETERS - MOREVIEW WINDOW

ENERGY	Thermal insulation EN 10077-2	Uw from 0.7 (Uf from 1.46)
COMFORT	Air permeability EN 12207	Class 4
	Watertightness EN 12208	900 Pa
SAFETY	Resistance to wind load EN 12210	Class C5/B5

TECHNICAL SPECIFICATION - MOREVIEW WINDOW

Frame installation depth	77 mm
Sash installation depth up to	88,5 mm
Infill thickness	46-50 mm
Maximum height H	3000 mm
Maximum width L	1600 mm
Maximum sash weight	180 kg
Construction type / sash configurations	fixed window, side-hung, tilt, tilt-and-turn, turn-and-tilt